

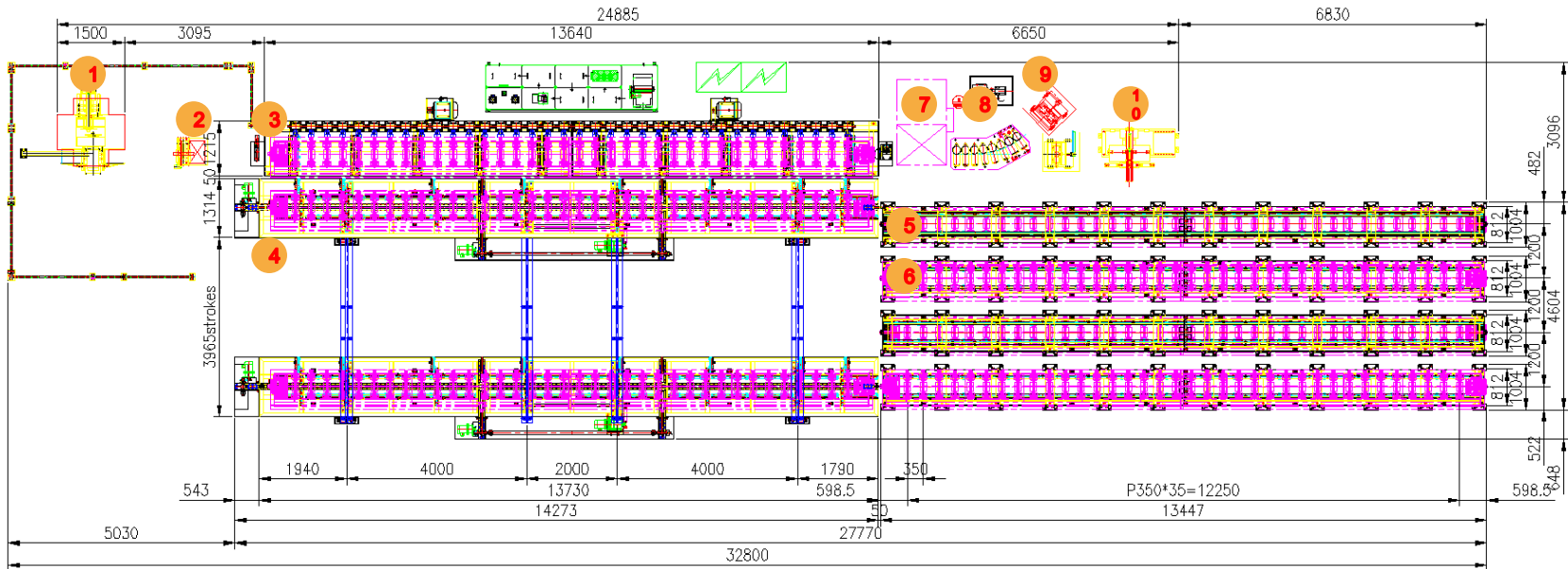

# LAY-OUT (SYSTEM)



Process	Specification	Process	Specification
1) Uncoiler	• Double Head	6) Cassette Stoker	• Stock a Cassette Kit
2) Shear & Joint Machine	• Hoop Shear & Coil Joint	7) Seam Welder	• Capacity : 500KVA
3) Roll Forming Machine	• 36 Stages	8) Round Bender	• Round & Twist & Leveller
4) Cassette Moving System	• Model Change By Feeding Cassette	9) Running Cutter	• Hyd' Cylinder Type
5) Stand Cassette Unit	• Upper, Rear, Outer, Q Channel	10) Unloading Conveyor	



# Product Process

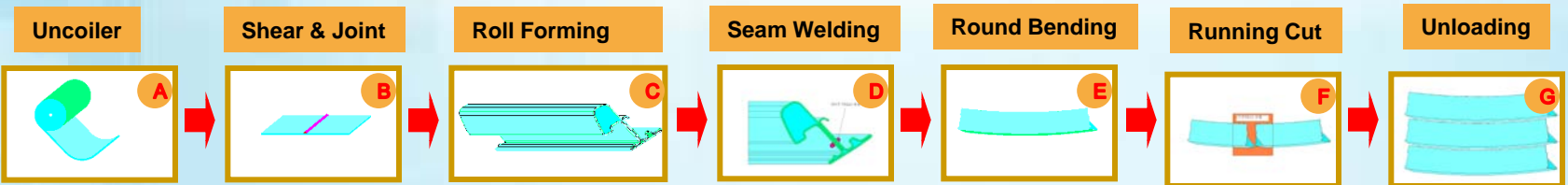
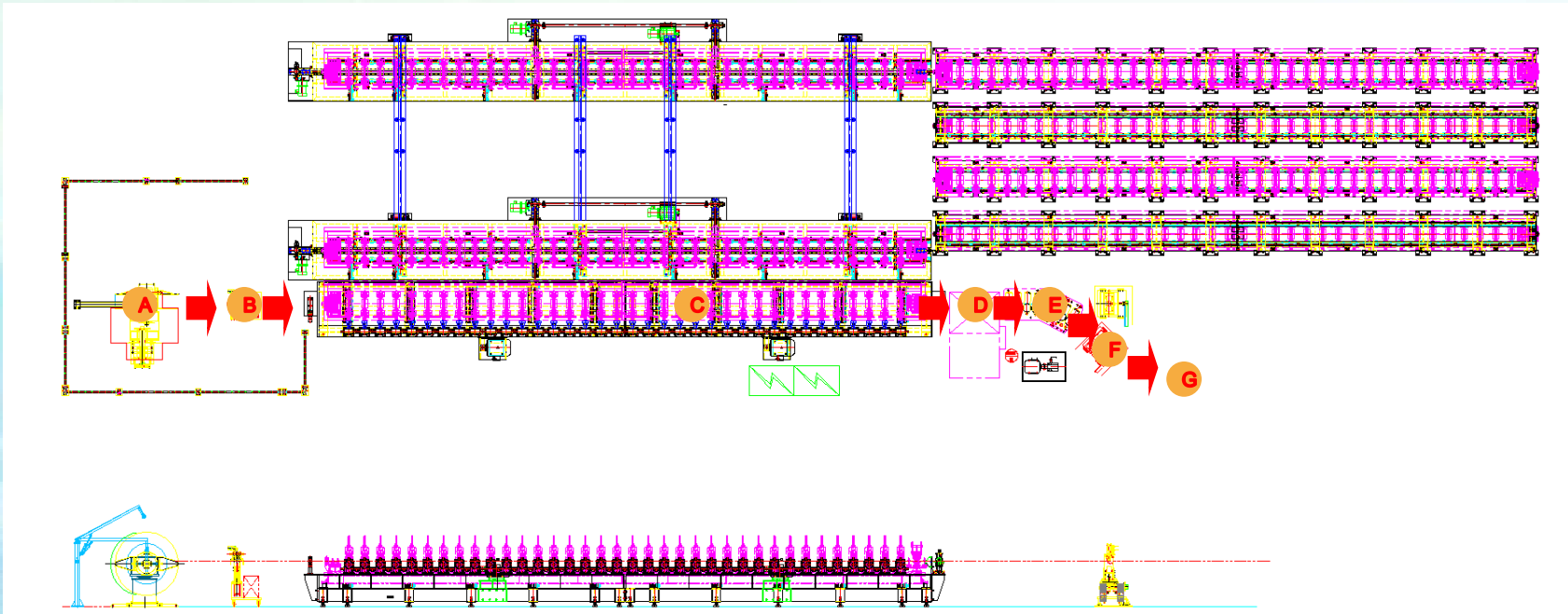



# EQUIPMENT Specification

## 1. Uncoiler M/C



### 1. Uncoiler M/C

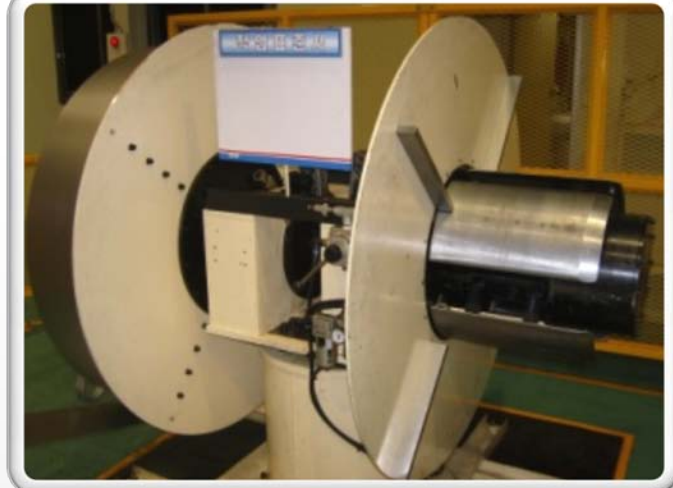
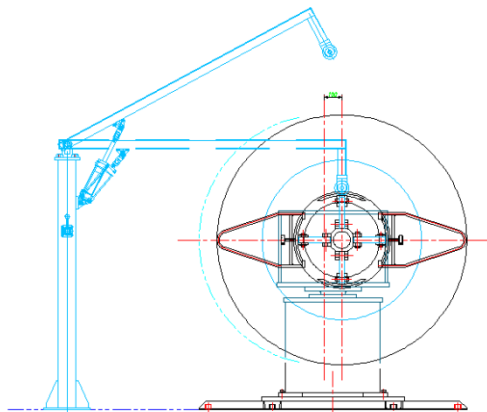
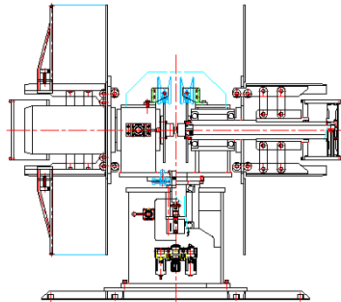
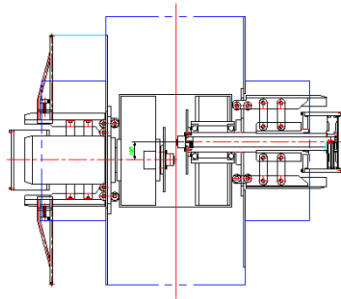



# EQUIPMENT Specification

## 2. Shear & Joint Machine

### 2. Shear & Joint Machine

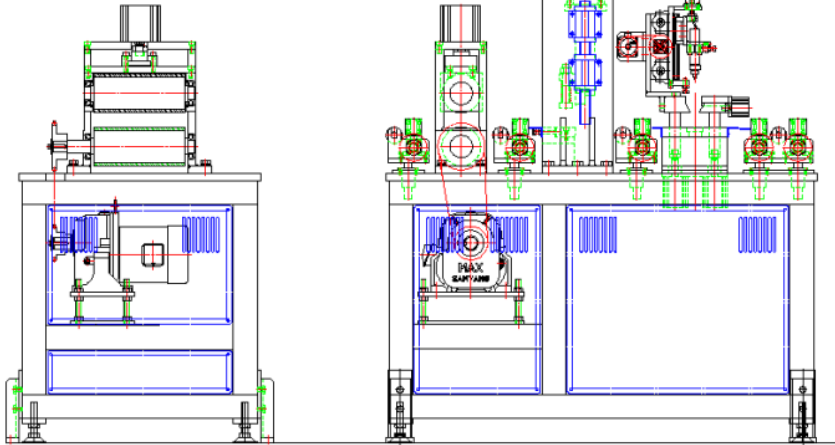
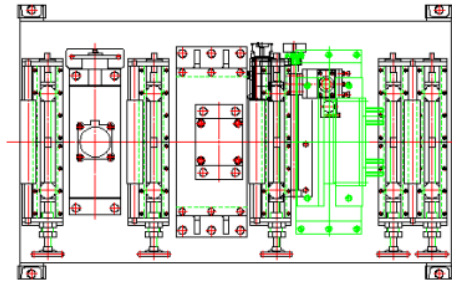





# EQUIPMENT Specification

## 3. Roll Forming Machine



### 3. Roll Forming Machine

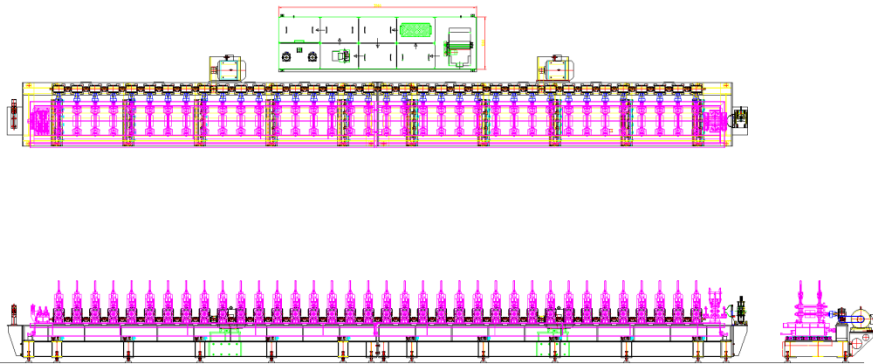



# EQUIPMENT Specification

## 4. Cassette Moving System



### 4. Cassette Moving System

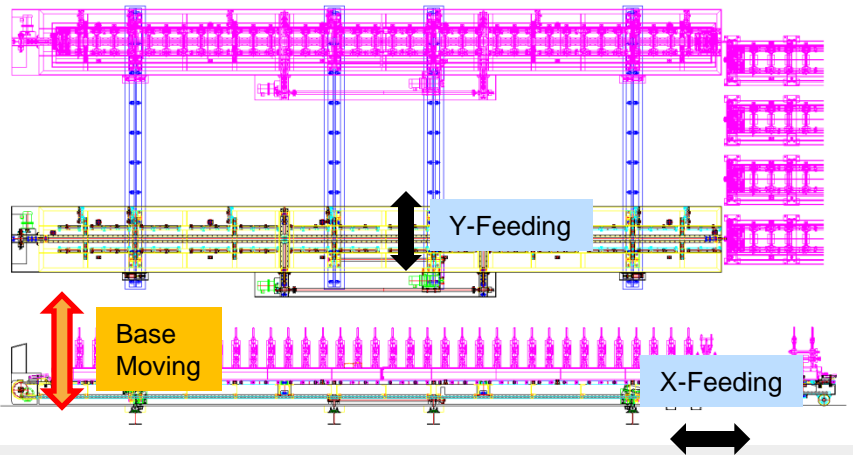



# EQUIPMENT Specification

## 5. Stand Cassette Unit



### 5. Stand Cassette Unit

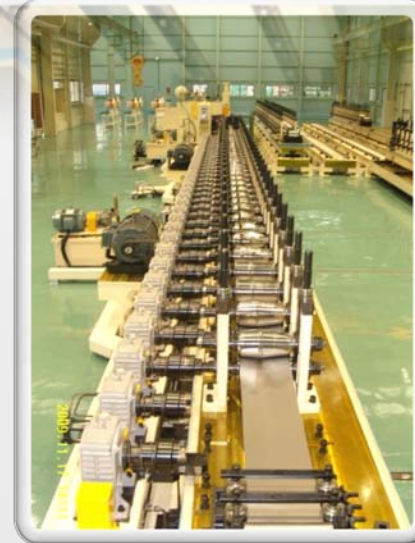
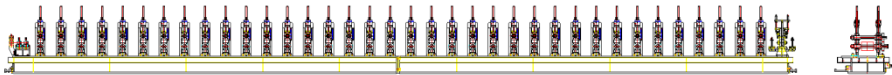
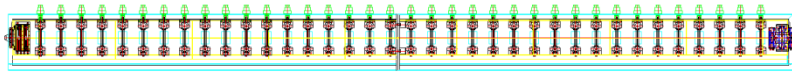





# EQUIPMENT Specification

## 6. Cassette Stocker



### 6. Cassette Stocker

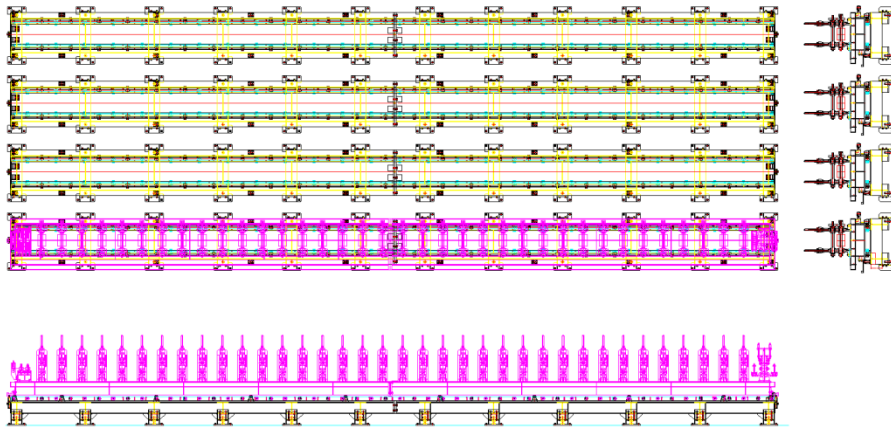





# EQUIPMENT Specification

## 7. Seam Welder



### 7. Seam Welder

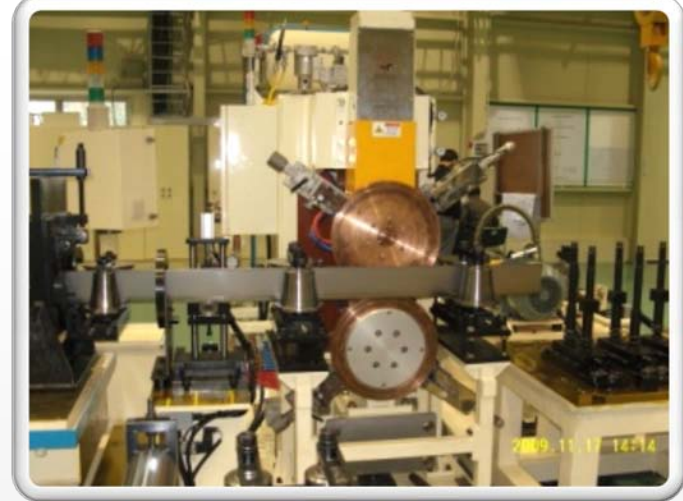
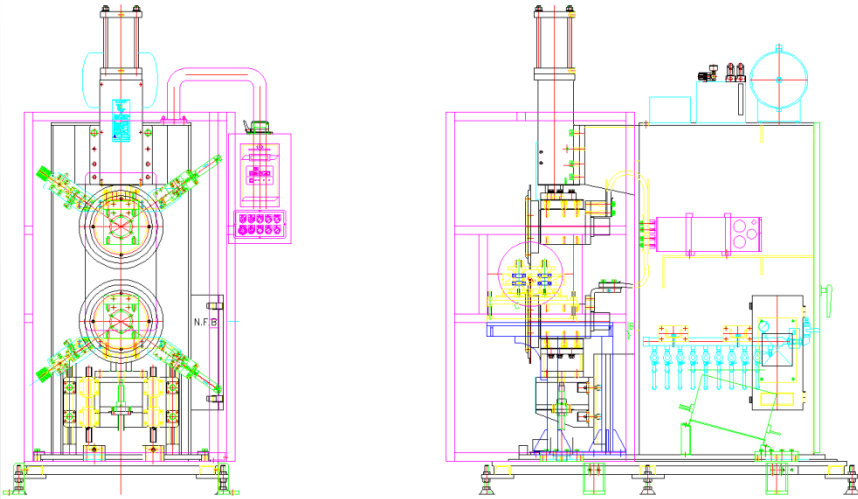



# EQUIPMENT Specification

## 8. Round Bender



### 8. Round Bender

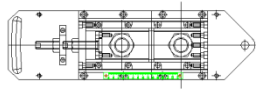

Round Roll

- 1~6 Stages

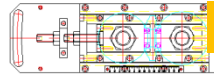
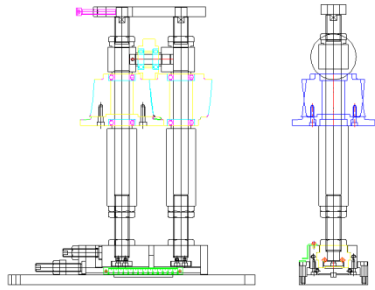

Twist Roll

- 7~8 Stages

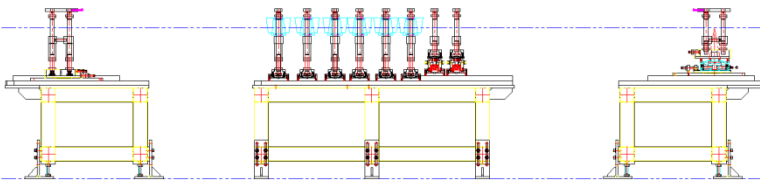
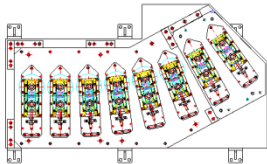
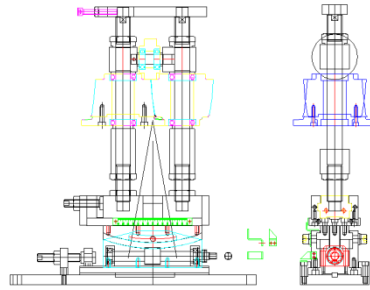



# EQUIPMENT Specification

## 9. Unloading Conveyor



### 9. Unloading Conveyor

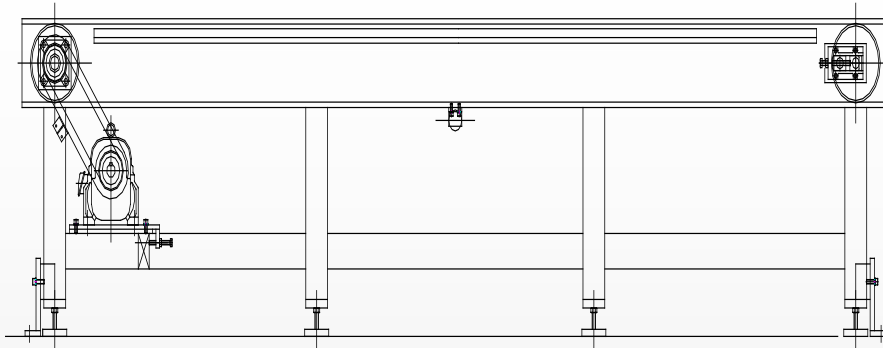





# PRODUCT INFORMATION

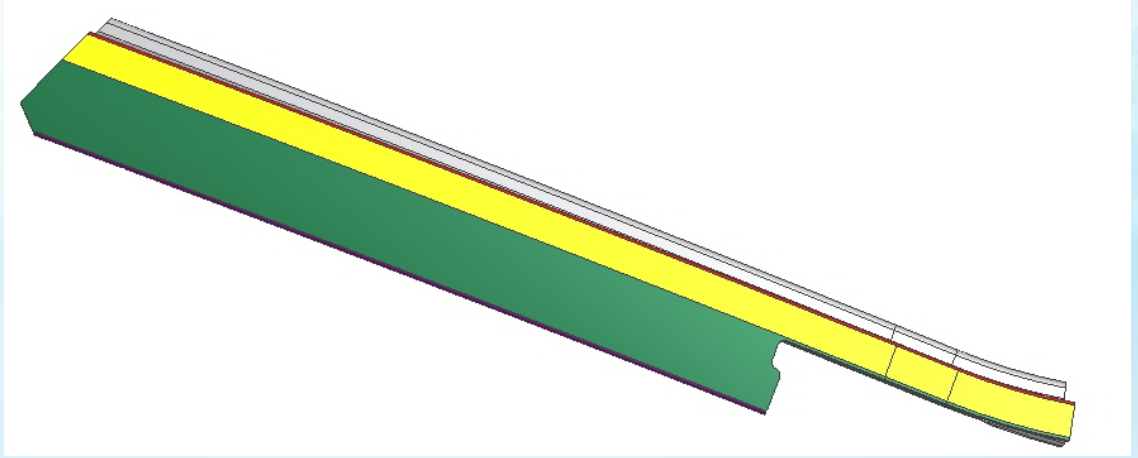
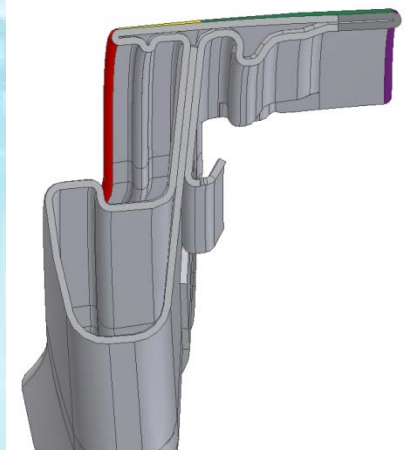
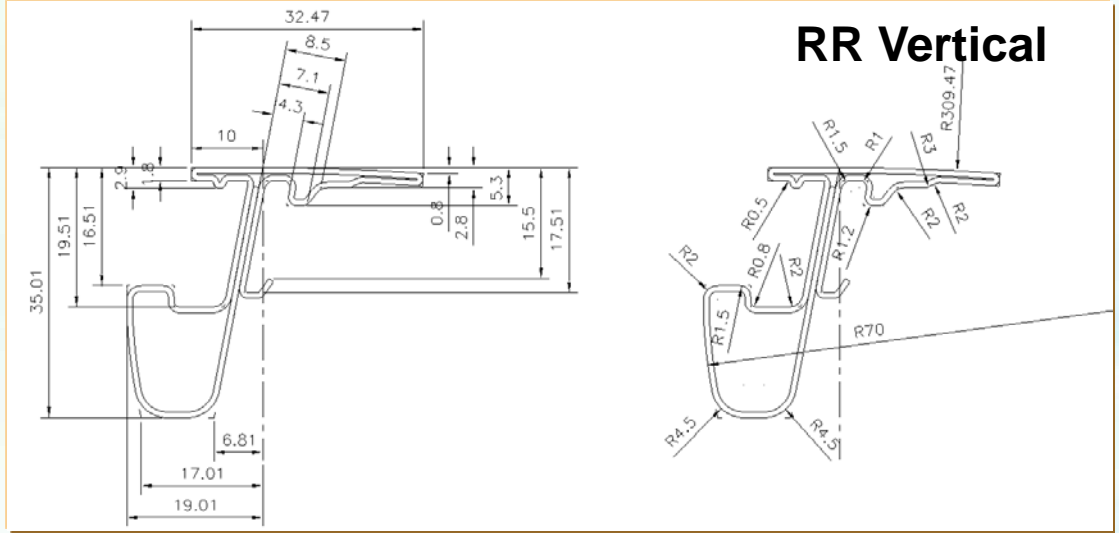
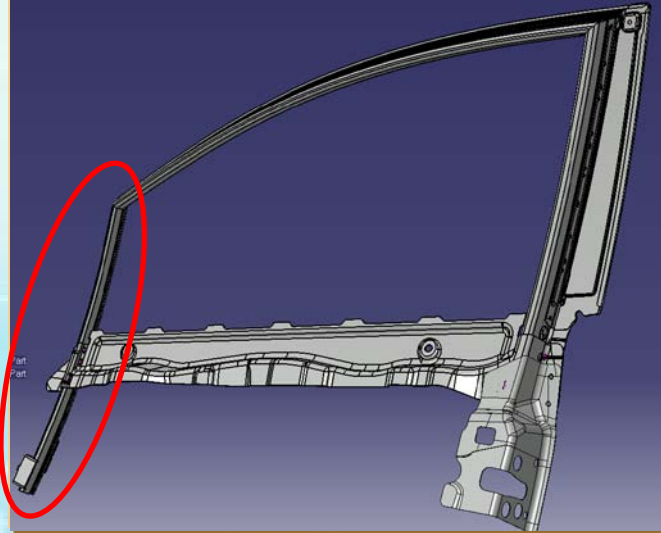



# PRODUCT INFORMATION

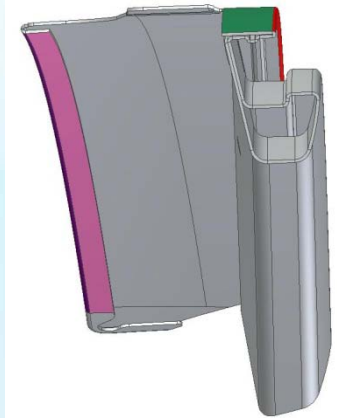
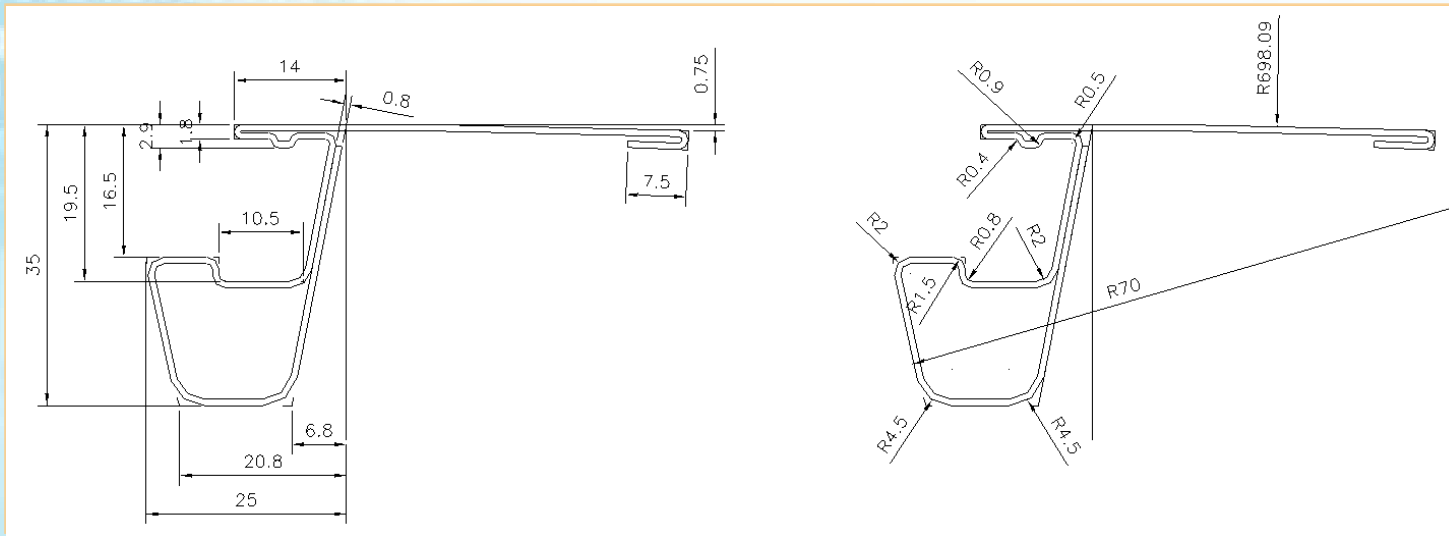
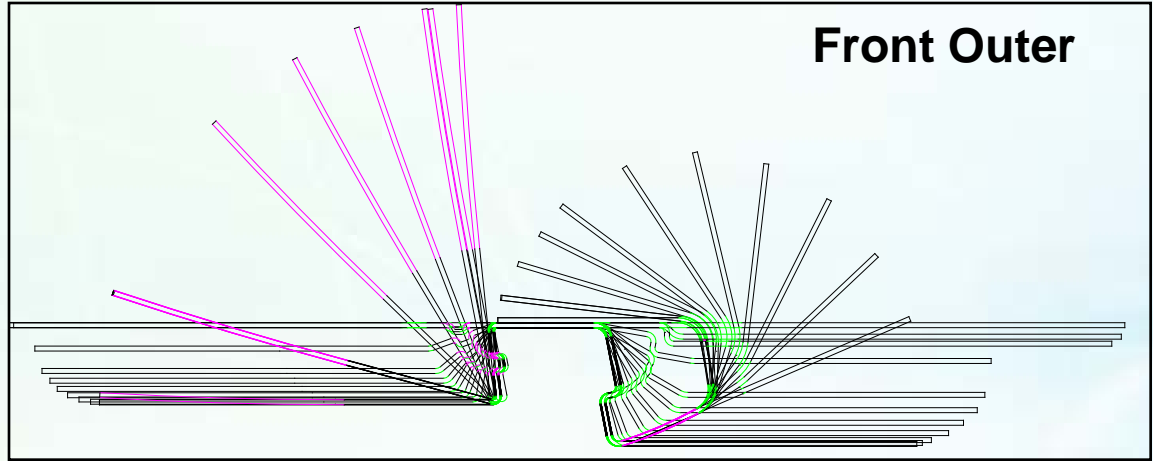
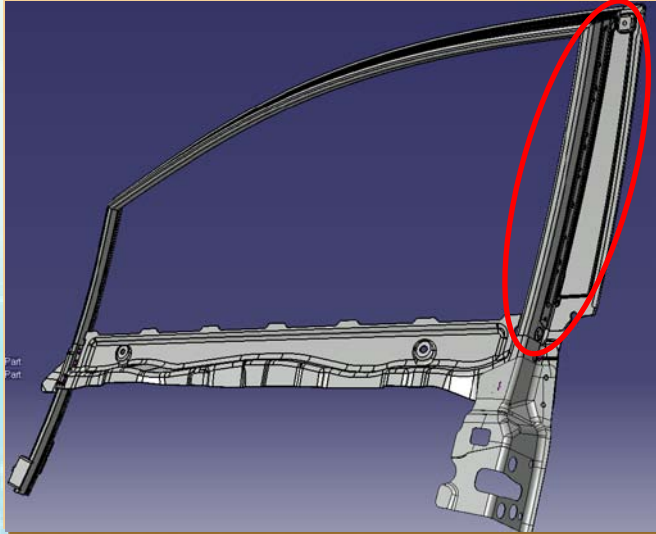



# PRODUCT INFORMATION

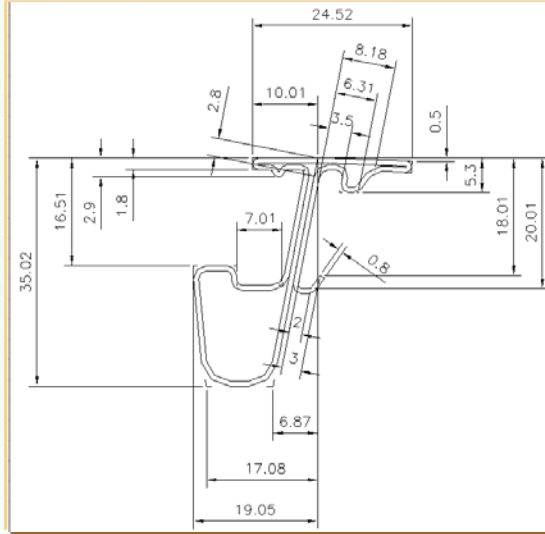
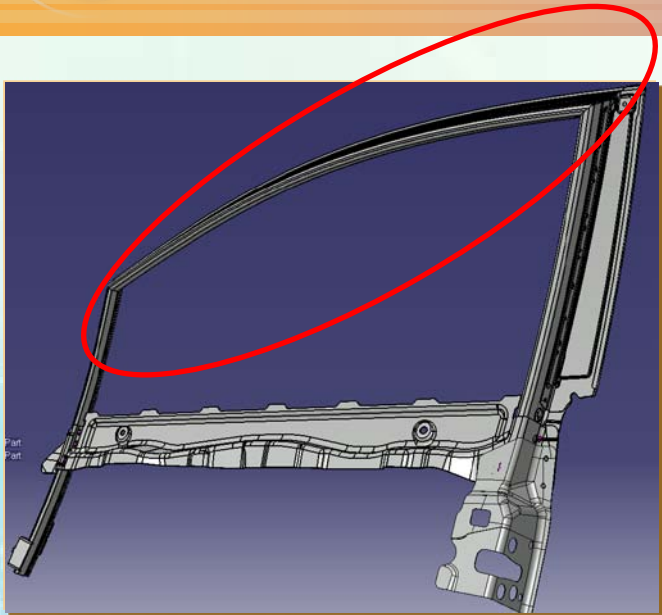

## Front Upper

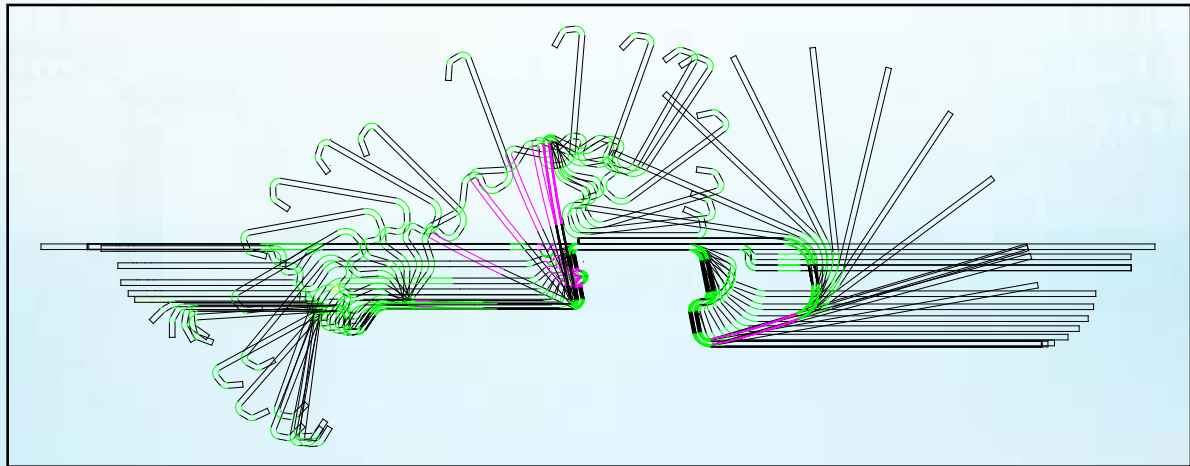
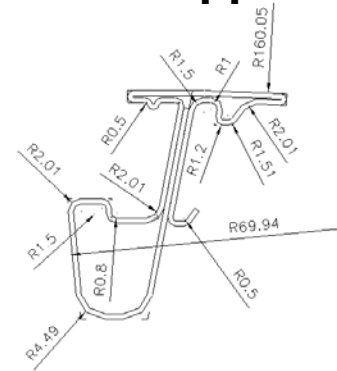





# PRODUCT INFORMATION

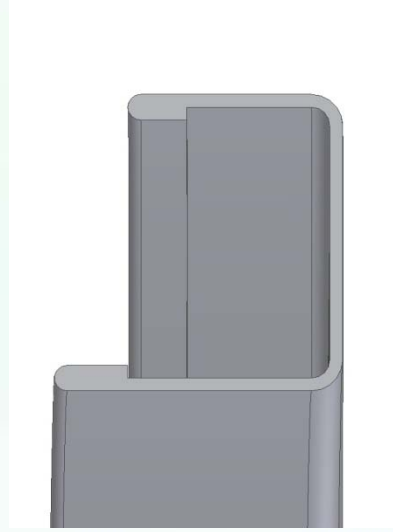
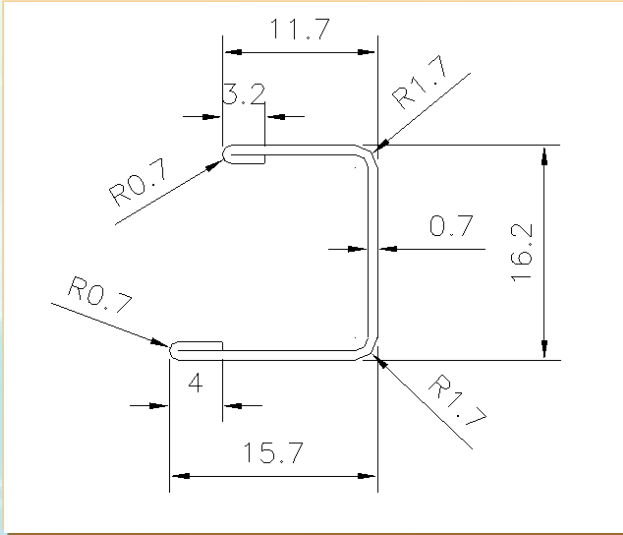

**Quadrant Channel**

